

TWILL SCARVES

Artwork Layout

NOTE: ART SHOWN AT 25%
Final Dimensions: 27.56" W X 27.56" H
Blue dotted line marks artwork safe zone
All artwork must bleed to red line
Black line marks product edge

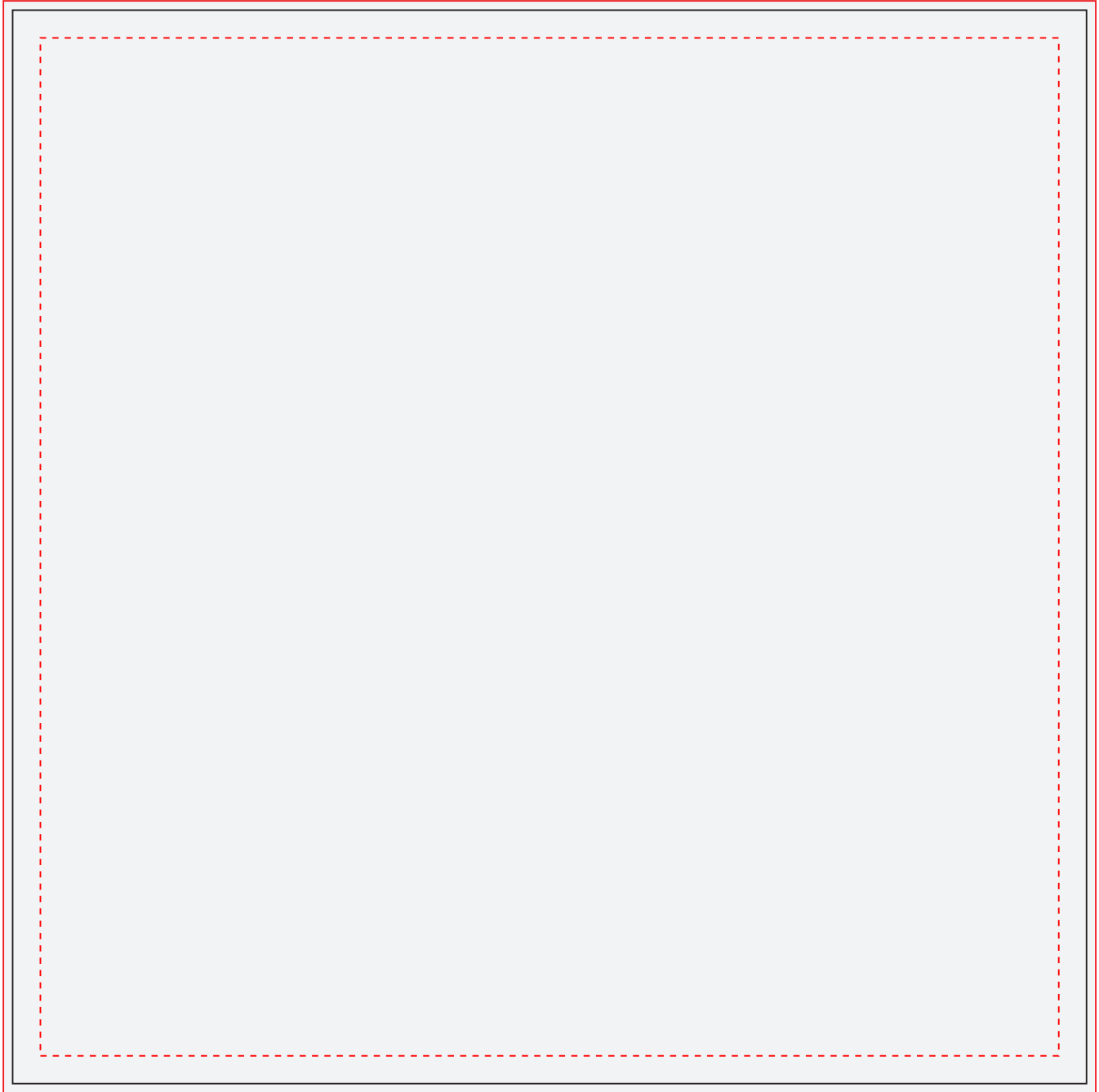

DESIGN NOTES

Base product is a 1 PMS color imprint on a white background
Up to 5 PMS colors can be added + white

PLEASE NOTE: ALL DESIGNS NEED TO BE REVIEWED FOR MANUFACTURABILITY

SC.21.1

TWILL SCARVES

WOVEN TAG

Artwork Layout

NOTE: ART SHOWN AT 100%
Final Dimensions: 1.0" W X 1.5" H
Blue dotted line marks artwork safe zone
Orange dotted line marks fold line
Black line marks product edge

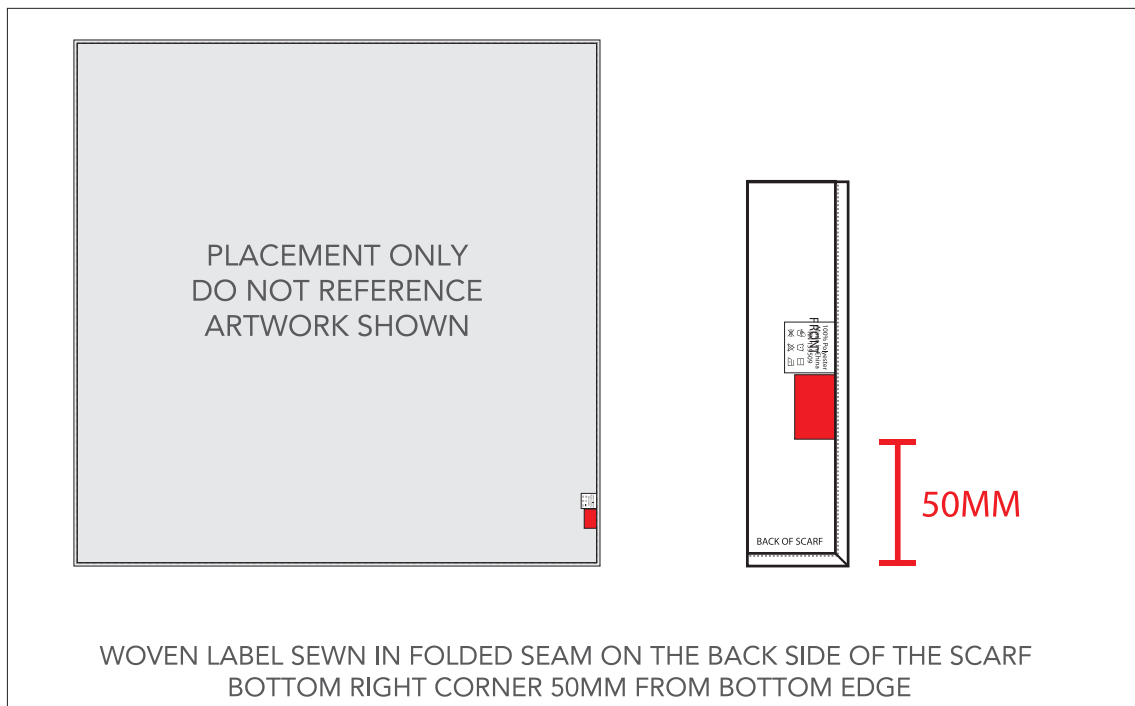
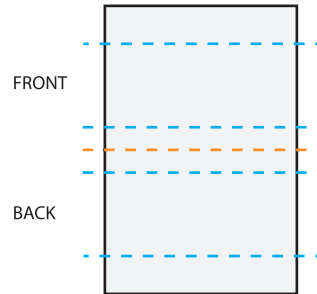

WOVEN LABEL SEWN IN FOLDED SEAM ON THE BACK SIDE OF THE SCARF
BOTTOM RIGHT CORNER 50MM FROM BOTTOM EDGE

DESIGN NOTES

Up to 7 Closest match colors can be used for woven tag

TWILL SCARVES

HANG TAG

Artwork Layout

NOTE: ART SHOWN AT 100%
Final Dimensions: 1.75" W X 2.875" H
Blue dotted line marks artwork safe zone
Black line marks product edge

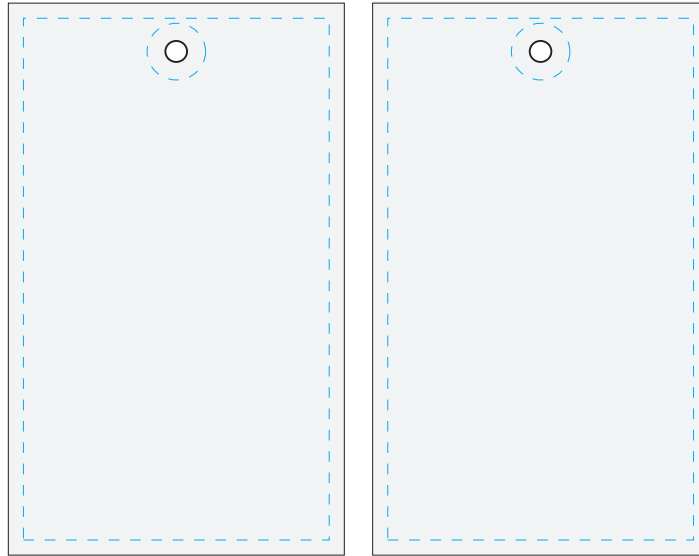

FRONT

BACK

PLACEMENT



DESIGN NOTES

Artwork will be CMYK printed

TWILL SCARVES

WRAP TAG

Artwork Layout

NOTE: ART SHOWN AT 60%
Final Dimensions: 10.71" W X 3.15" H

Blue dotted line marks artwork safe zone
All artwork must bleed to red line
Orange dotted line marks fold line
Black line marks product edge

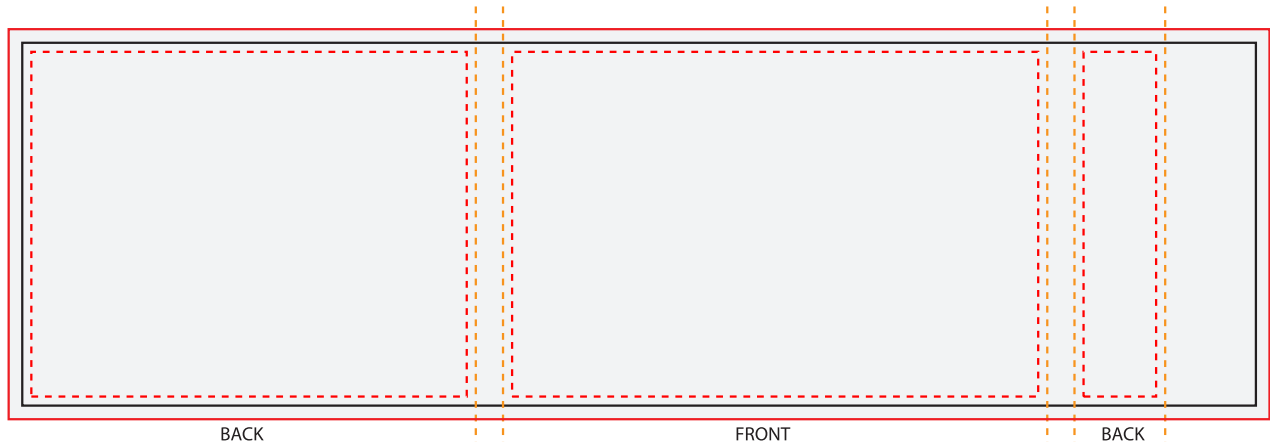

Artwork will be covered
right of dotted line

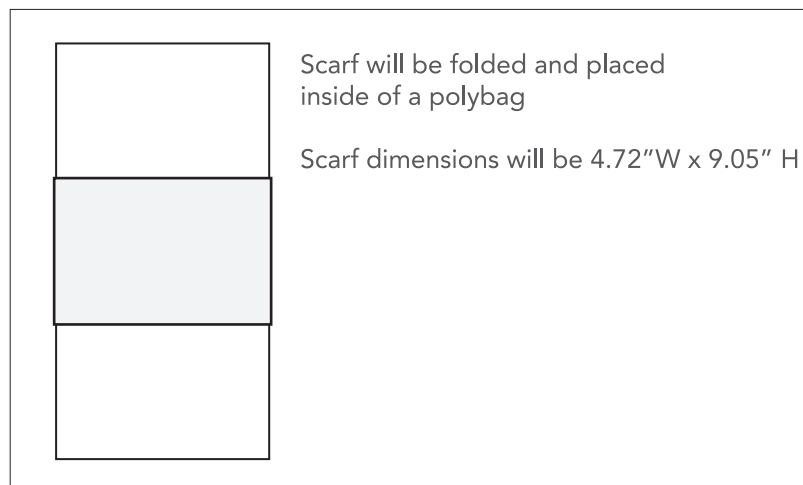

DESIGN NOTES

Artwork will be CMYK printed

TWILL SCARVES

CUSTOM GIFT ENVELOPE

Artwork Layout

NOTE: ART SHOWN AT 40%
Folded Dimensions: 6.1" W X 6.1" H
Unfolded Dimensions: 9.65" W X 15.08" H
Blue dotted line marks artwork safe zone
All artwork must bleed to red line
Orange dotted line marks fold line
Black line marks product edge

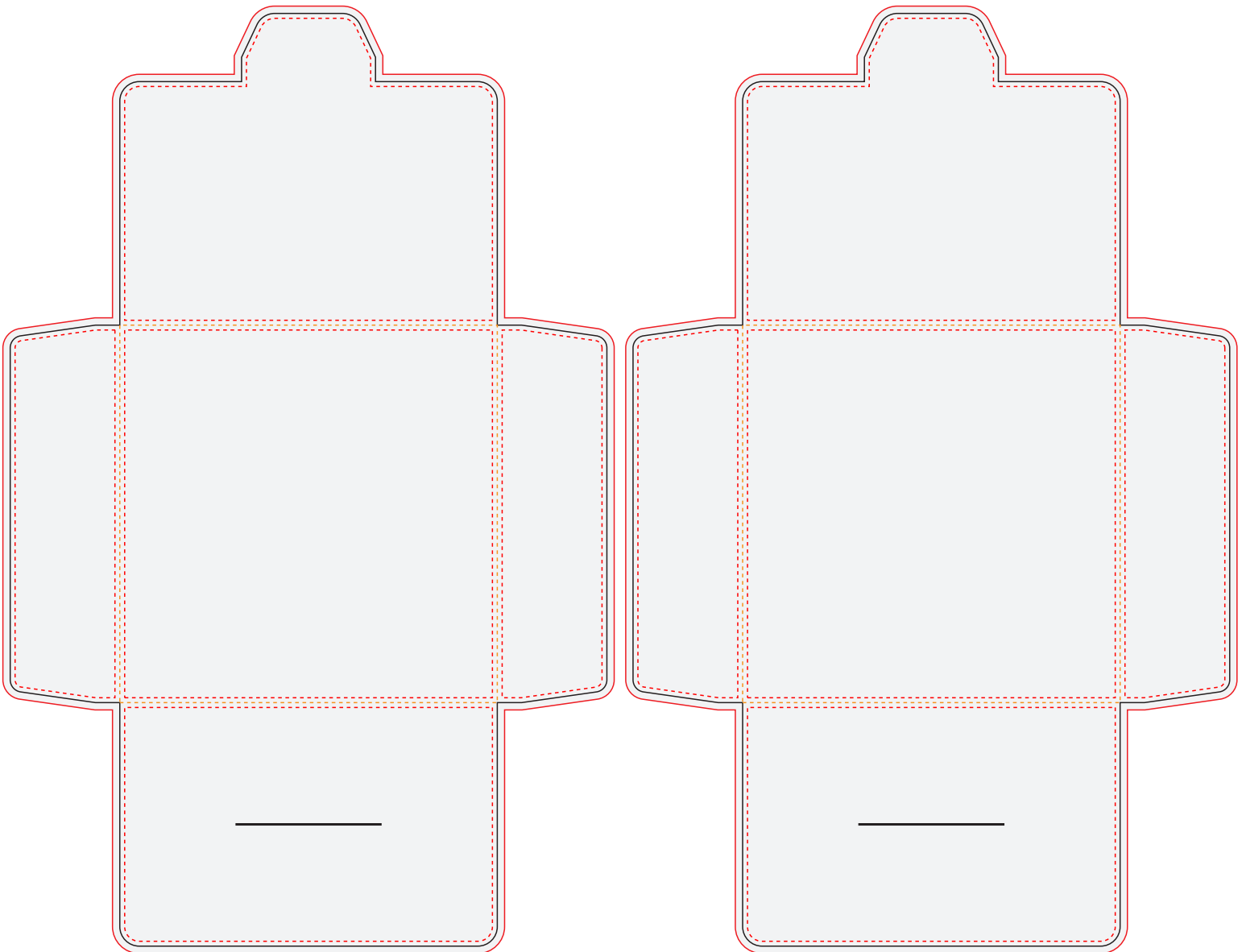

EXTERIOR PRINTING

INTERIOR PRINTING

DESIGN NOTES

Artwork will be CMYK printed



TWILL SCARVES DECORATION GUIDE



Our new Twill Scarves are a great multi-use product for displaying your unique branding with vibrant designs!

BASE PRODUCT

The base product decoration includes one Pantone matched color on a white background.

As long as your design meets our standard minimums, you won't have **any issues with artwork limitations!**



PRINTING LIMITATIONS

Specific overlapping colors can lead to color bleeds that look like outlines around design elements.

Original Vector Artwork

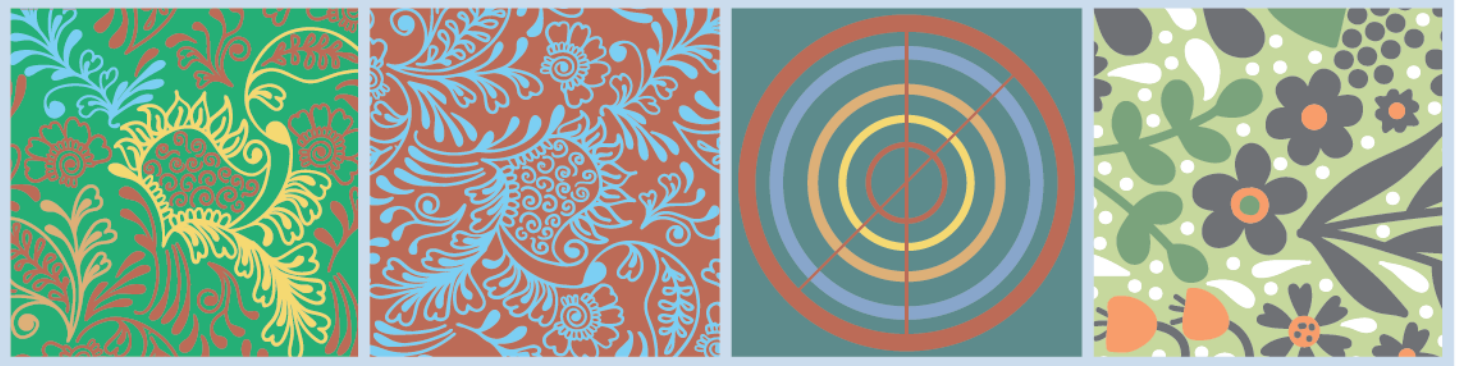

Printed Artwork



Let us help you avoid these issues!

Our Art Gurus are here to set you up for success by following the guidelines on the next few pages.



PRO TIP #1

You can adjust your design with a white or dark stroke between overlapping colors

Original Design

The overlapping reds, blues and yellows in these designs are going bleed into each other



Modified Designs

Change to a white background, or add a white outline between any overlapping colors



Change to a dark background, or add a dark stroke over any overlapping colors

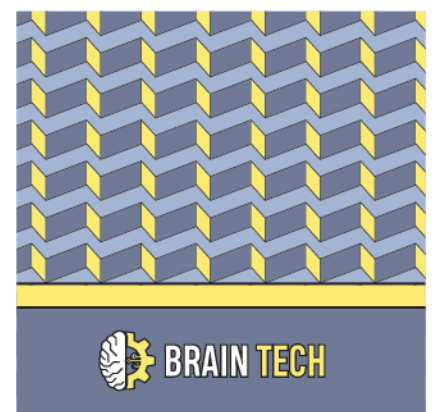
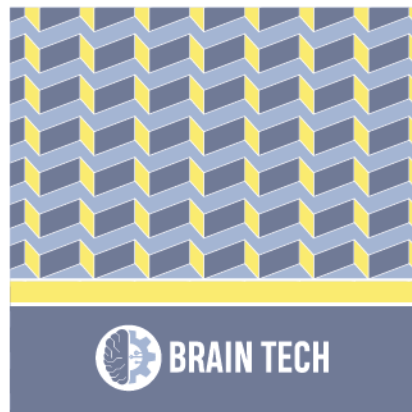



PRO TIP #2

If you need to overlap colors, keep them within the same part of the color wheel

Designing within the same part of the color wheel will reduce the likelihood of color overlap creating an obvious bleed effect.

Original Design



Modified Designs

